

NON-MAGNETIC TOUCH LATCH

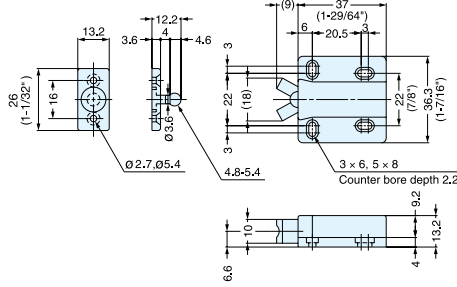

MC-28



- Push to latch/unlatch.
- Touch latch with floating strike allows for easy alignment.

Note:

- For overlay door, allow 3 mm (1/8") gap between door and cabinet frame for push space.
- Pulling door with excessive force without unlatching the unit may damage the mechanism.
- Constant loading of over 3 kgf or excessive pushing or pulling is not recommended.

Item No.	Retaining Force (kg)	Weight (g)	Box (pcs)	Carton (pcs)
MC-28/BLK	3 (6.6 lbs)	15	50	500

Part Name	Material	Color
Body	ABS	Black
Arm	Polyacetal	
Strike	Polyamide	

NON-MAGNETIC TOUCH LATCH



PR-21P/BLK

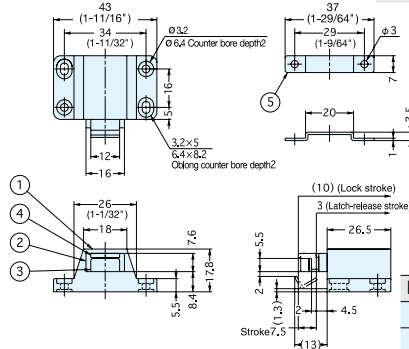

- Push to latch/unlatch.
- Strong retaining force.

Item No.	Retaining Force (kg)	Weight (g)	Box (pcs)	Carton (pcs)
PR-21P/BLK	10 (22 lbs)	16.3	100	800

No.	Part Name	Material	Finish/Color
①	Housing	ABS	Black
②	Slide	Polyacetal	
③	Arm	Steel	Brown
④	Yoke		GB
⑤	Strike		Chromate

NON-MAGNETIC TOUCH LATCH



PR-3PK

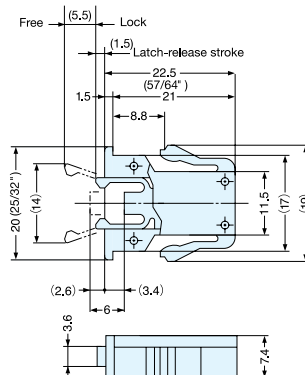

- Push to latch/unlatch.
- Thin design is ideal for tight spaces.
- Snap-in style catch.
- Strike/Counterplate not available.

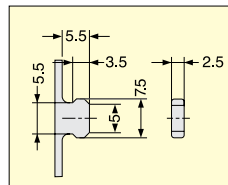

Recommended Strike Dimension

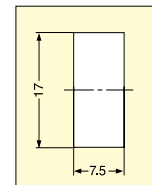

Cut Out Dimensions

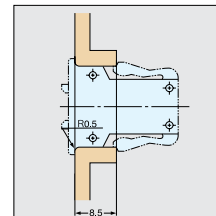

Installation

Item No.	Retaining Force (kg)	Weight (g)	Box (pcs)	Carton (pcs)
PR-3PK	2.2 (4.8 lbs)	2.5	400	4000

Material	Color
ABS	Black